



Research Article

Copyright© Emin Taner ELMAS

# Project for “Amphibious Mobile Snow Track Ambulance” for Healthcare System

**Emin Taner ELMAS\***

Assistant Professor Dr., Vocational School of Higher Education for Technical Sciences, Division of Motor Vehicles and Transportation Technologies, Department of Automotive Technology, Iğdır University, Turkey & Graduate School of Natural and Applied Sciences - Major Science Department of Bioengineering and Bio-Sciences, Iğdır University, Turkey

\*Corresponding author: Emin Taner ELMAS, Assistant Professor Dr., Vocational School of Higher Education for Technical Sciences, Division of Motor Vehicles and Transportation Technologies, Department of Automotive Technology, Iğdır University, Turkey & Graduate School of Natural and Applied Sciences - Major Science Department of Bioengineering and Bio-Sciences, Iğdır University, Turkey.

To Cite This Article: Emin Taner ELMAS\*. Project for “Amphibious Mobile Snow Track Ambulance” for Healthcare System. Am J Biomed Sci & Res. 2024 22(4) AJBSR.MS.ID.002990, DOI: 10.34297/AJBSR.2024.22.002990

Received: 📅: May 20, 2024 ; Published: 📅: May 23, 2024

## Abstract

This article explains an “Amphibious Mobile Snow Track Ambulance Project” which is technically designed and managed by Asst. Prof. Dr. Emin Taner ELMAS, who is the Department Head of Division of Motor Vehicles and Transportation Technologies, Department of Automotive Technology, at Vocational School of Higher Education for Technical Sciences of Iğdır University, Turkey.

The mentioned “Amphibious Mobile Snow Track Ambulance” is mainly a “tracked vehicle” so it can easily be driven on the snow. In addition, this vehicle shall have a snow plough in order to sweep the snow on the roads. Another important feature of this vehicle is to have an amphibious structure, that means the ambulance can also swim in the water lakes.

Amphibious Mobile Snow Track Ambulance will also be a Project model which can be applied for the whole provinces and regions at which winter is heavy, like Eastern Anatolian Region of Turkey. By implementation of this Project provides a timely healthcare response for the patients and will save their lives.

The Project will be started by Iğdır University at Iğdır Province of Turkey and then aimed to be made widespread in use all over the Eastern Anatolian Region of Turkey [1-15].

**Keywords:** Automotive, Amphibious vehicle, Tracked vehicle, Snow ambulance, Ambulance, Snow track, Healthcare system

## Introduction & Method, Findings and Discussion & Conclusion

At the regions at which winter is heavy, like Eastern Anatolian Region of Turkey, the village roads are closed due to intensive snowfall, therefore it may not be possible to take the patients who live in those villages, to the hospitals or healthcare centers on time. The conventional rubber-tyred ambulances cannot get ahead on the village roads which are closed due to intensive snowfall. Therefore, it may not be possible to realize a timely healthcare response for the patients. Besides, some patients may lose their lives.

Thanks to the “PROJECT FOR AMPHIBIOUS MOBILE SNOW TRACK AMBULANCE FOR HEALTHCARE SYSTEM” it is aimed to

prevent such damaging situations. The Amphibious Mobile Snow Track Ambulances are build-up in order to stock them at village administration mukhtar and their main duty is to carry the patients to the hospitals or healthcare units under the heavy snowy winter conditions.

The mentioned ambulance is mainly a “tracked vehicle” so it can easily be driven on the snow. In addition, this vehicle shall have a snow plough in order to sweep the snow on the roads. Another important feature of this vehicle is to have an amphibious structure, that means the ambulance can also swim in the water lakes. Therefore, thanks to the project, an amphibious mobile snow track



ambulance shall have been produced. The ambulance shall have a driver seat, a stretcher for the patient and a seat for the care person at the back side of the vehicle. The snow track ambulance will be equipped with the fundamental medical units and required healthcare devices. The Project will be started by Iğdır University at Iğdır Province of Turkey and then aimed to be made widespread in use all over the Eastern Anatolian Region of Turkey. Manufacturing of such an Amphibious Mobile Snow Track Ambulance will also be a Project model which can be applied for the whole provinces and regions at which winter is heavy. By implementation of this Project provides a timely healthcare response for the patients and will save their lives.

This "Amphibious Mobile Snow Track Ambulance Project" is technically designed and managed by Asst. Prof. Dr. Emin Taner ELMAS, who is the Department Head of Division of Motor Vehicles and Transportation Technologies, Department of Automotive Technology, at Vocational School of Higher Education for Technical Sciences of Iğdır University, Turkey.

Figure 1 and Figure 2 shows "Amphibious Mobile Snow Track Ambulance" for healthcare system. Figure 3 and Figure 4 shows various perspective views of Amphibious Mobile Snow Track Ambulance. Figure 5, Figure 6, Figure 7 and Figure 8 shows the general production dimensions for Amphibious Mobile Snow Track Ambulance [1-15].

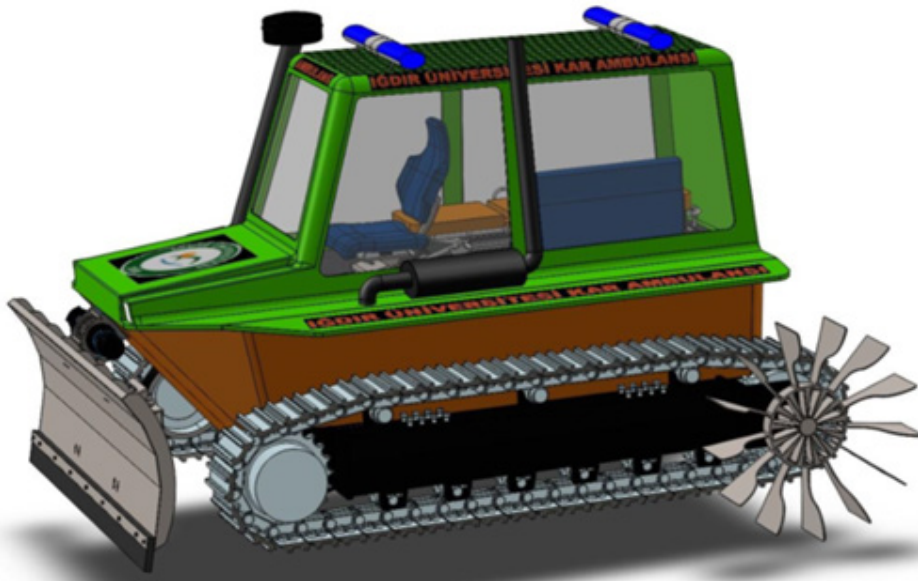

Figure 1: Amphibious Mobile Snow Track Ambulance for healthcare system.



Figure 2: Amphibious Mobile Snow Track Ambulance for healthcare system.

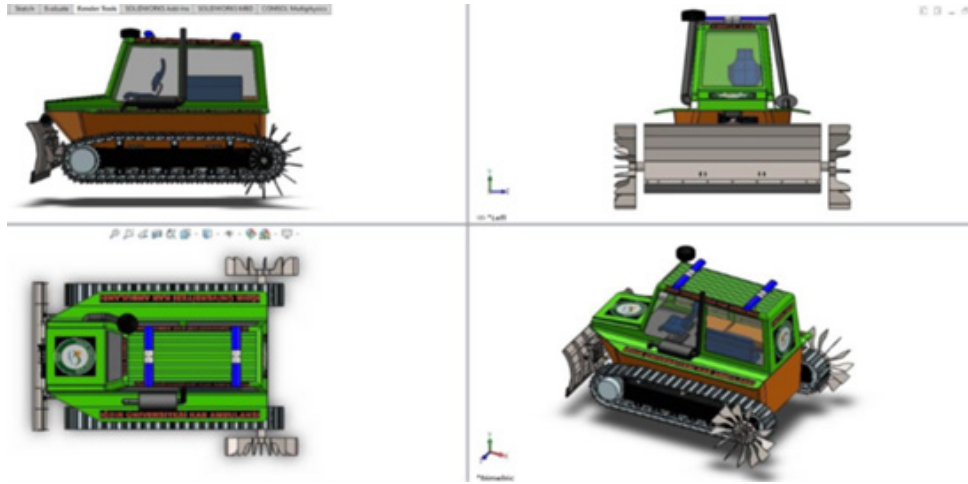

Figure 3: Various perspective views of Amphibious Mobile Snow Track Ambulance.

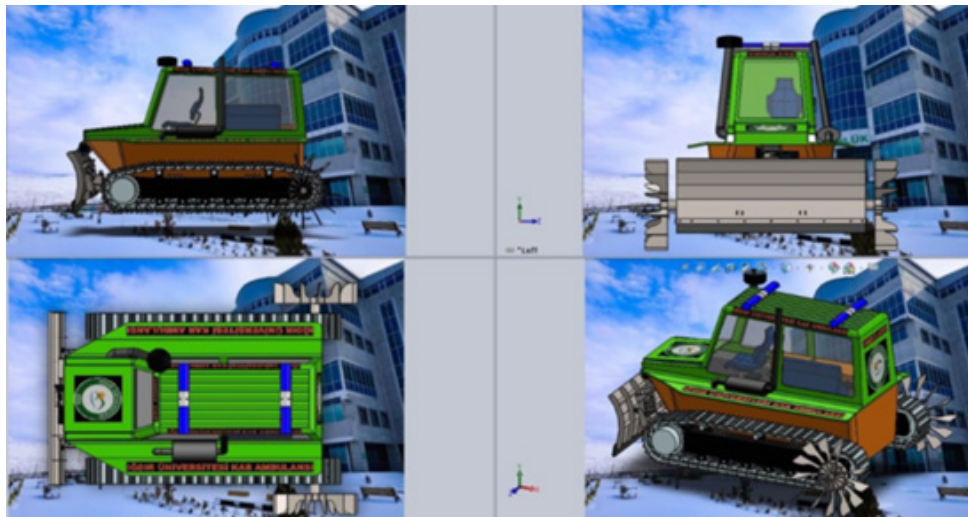

Figure 4: Various perspective views of Amphibious Mobile Snow Track Ambulance.

Proje: IĞDIR ÜNİVERSİTESİ AMFİBİK MOBİL PALETLİ KAR AMBULANSI

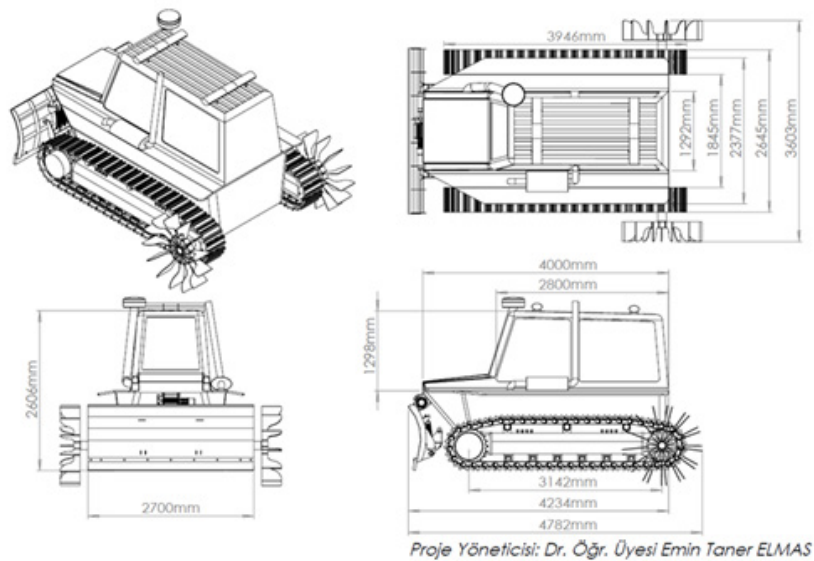

Figure 5: General production dimensions for Amphibious Mobile Snow Track Ambulance.

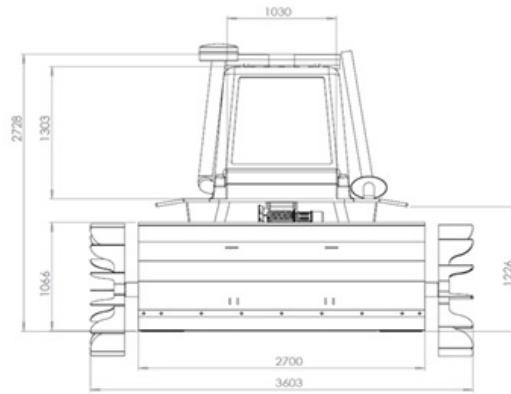

Figure 6: General production dimensions for Amphibious Mobile Snow Track Ambulance.

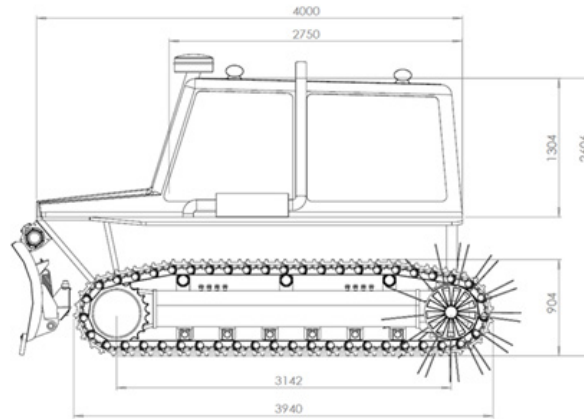

Figure 7: General production dimensions for Amphibious Mobile Snow Track Ambulance.

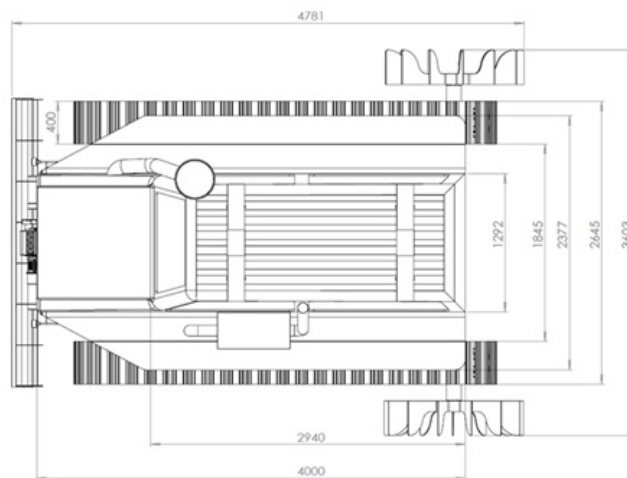

Figure 8: General production dimensions for Amphibious Mobile Snow Track Ambulance.



## References

1. Emin Taner E (2023) Thermodynamical And Experimental Analysis of Design Parameters of a Heat Pipe Air Recuperator. *Global Journal of Research in Engineering & Computer Sciences* 3(6): 6-33.
2. Elmas, Emin Taner (2019) Thermodynamical Balance Associated with Energy Transfer Analysis of the Universe Space as a Pressure Vessel Analogy. *Journal of Applied Sciences, Redelve International Publications* 2019(1): RDAPS-10002.
3. Elmas Emin Taner (2017) Productivity and Organizational Management (The Book) (Chapter 7): Prospective Characteristics of Contemporary Engineer (By the Approach of Mechanical Engineering) Contribution and Role of the Mechanical Engineer to the Organization Management and Productivity. Machado Carolina, Davim J Paulo (Eds.), DEGRUYTER, Walter de Gruyter GmbH, Berlin / Boston, Spain (ISBN:978-3-11-035545-1)
4. Elmas, Emin Taner (2017) Prospective Characteristics of Contemporary Engineer (By the Approach of Mechanical Engineering) Contribution and Role of the Mechanical Engineer to the Organization Management and Productivity). DeGruyter, Germany.
5. Elmas Emin Taner (2017) Evaporation Plant for Recycling of Caustic Soda, *INTERNATIONAL JOURNAL of ENGINEERING TECHNOLOGIES-IJET* Emin Taner Elmas 3(3).
6. Elmas Emin Taner (2014) *Çağımızın Mühendisinden Beklenenler, Gece Kitaplığı*, ISBN: 9786053244158
7. Emin TE (2023) Design, Production, Installation, Commissioning, Energy Management and Project Management of an Energy Park Plant Consisting of Renewable Energy Systems Established at Iğdır University. In *Global Journal of Research in Engineering & Computer Sciences* 3(6): 67-82.
8. (2020) Iğdır Üniversitesi, Basın Yayın Merkezi Haberi 1: "Amfibik Özellikli Mobil Paletli Kar Ambulansı Projesi"; "Öğr. Üyesi Emin Taner Elmas 'Amfibik Mobil Paletli Kar Ambulansı' Projesini Anlattı.
9. BAP PROJECT APPLICATION: "AMPHIBIC FEATURED MOBILE TRACKED SNOW AMBULANCE PROJECT", Iğdır University, Research Project, Project Number: TBY1120A26.
10. Hasan TAMSÖZ, Emin Taner ELMAS (2021) INVESTIGATION ON ENERGY COSTS AND ENERGY EFFICIENCY FACTORS OF ELECTRIC ARC FURNACE FOR STEEL PRODUCTION, *Fenerbahçe Üniversitesi Tasarım, Mimarlık ve Mühendislik Dergisi - Journal of Design, Architecture & Engineering* 1(3): 163-180
11. Adem KAYA, Emin Taner ELMAS (2022) DETERMINATION OF ENERGY UTILIZATION POINTS AND THE METHODS USING THE EFFICIENT ENERGY FOR SINTERING PLANTS, *Fenerbahçe Üniversitesi Tasarım, Mimarlık ve Mühendislik Dergisi - Journal of Design, Architecture & Engineering* 2(2): 170-181.
12. Emin Taner ELMAS (2024) The Electrical Energy Production Possibility Research Study by using the Geothermal Hot Water Resources, which is a kind of Renewable Energy Resource, located at the Region of Mollakara Village which is a part of Diyadin Town and City of Ağrı, Turkey. In *Global Journal of Research in Engineering & Computer Sciences* 4(1): 90-101.
13. ELMAS Emin Taner (2024) Energy Analysis, Energy Survey, Energy Efficiency and Energy Management Research carried out at Iğdır University. In *Global Journal of Research in Engineering & Computer Sciences* 4(2): 12-30.
14. ELMAS, Emin Taner (2024) A Research Study of Salt Dome (Salt Cave) Usage Possibility for CAES - Compressed Air Energy Storage Systems. In *Global Journal of Research in Engineering & Computer Sciences* 4(2): 128-131.
15. ELMAS Emin Taner (2024) Wankel Rotary Piston Engine Design Project. In *Global Journal of Research in Engineering & Computer Sciences* 4(3): 1-4.